

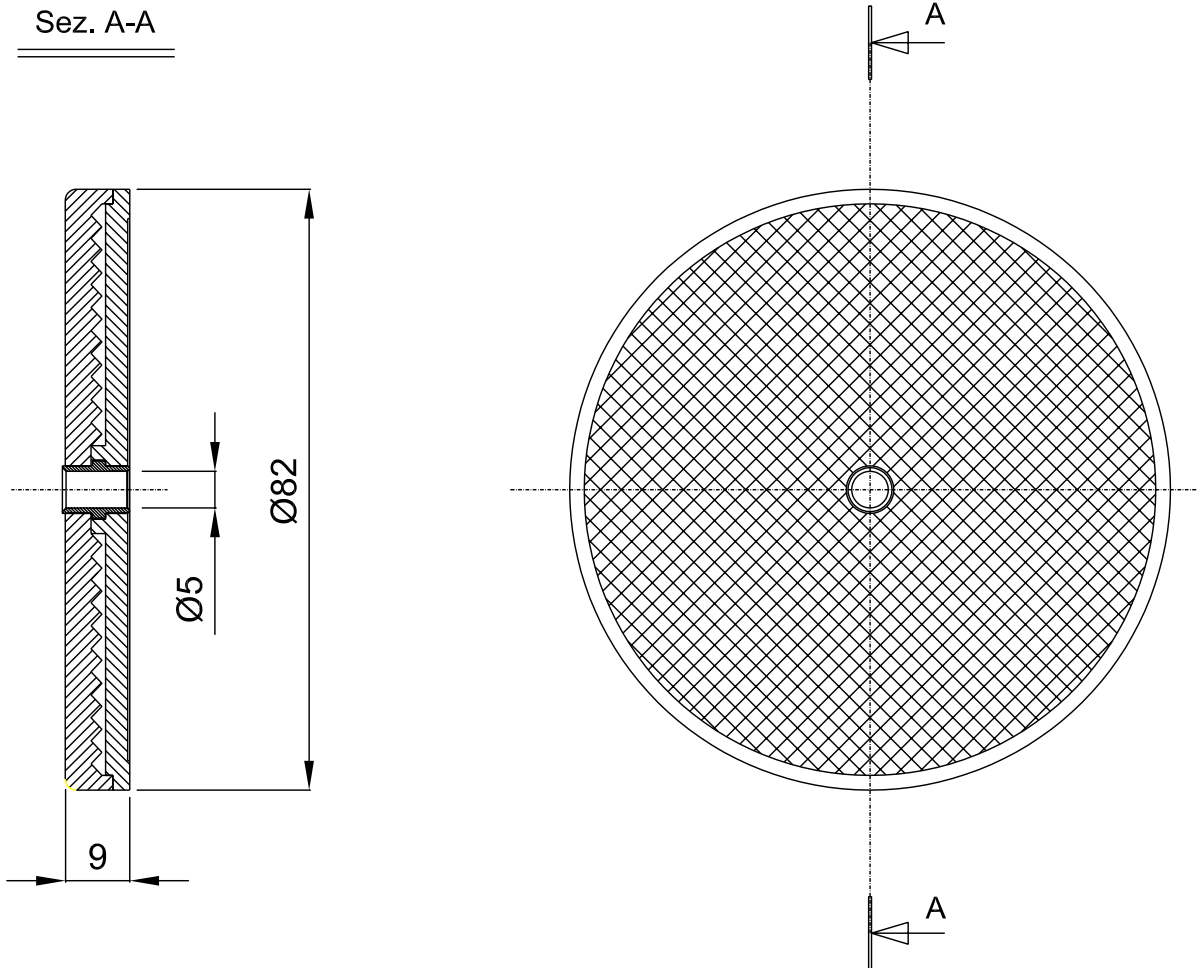

This document, technical information and specification contained herein are proprietary and must not be used, copied, reproduced, or otherwise dealt with nor communicated to others except in accordance with written instructions received from DATASENSOR S.p.A.
 Questo documento, le informazioni tecniche e le specifiche in esso contenute sono da considerarsi confidenziali e non devono essere utilizzate, copiate, riprodotte o trattate diversamente, né comunicate ad altri, se non in seguito ad istruzioni scritte ricevute da DATASENSOR S.p.A.

Sez. A-A

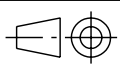

MOD.	REV.	PROPOSTA	DESCRIZIONE		DATA	FIRMA			
QUOTE SENZA TOLLERANZA GRADO DI PRECISIONE:			NOTE						
GRADO DI PRECISIONE	GRUPPI DI DIMENSIONI					SCALA 1:1			
	> 0 A 6	> 6 A 30	> 30 A 120	> 120 A 315	> 315 A 999			TRATT.	
MEDIO	±0.1	±0.2	±0.3	±0.5	±0.8	MATER.			
PRECISO	±0.05	±0.1	±0.15	±0.2	±0.3	DIS.DA M.MORETTI DATA 04/03/99	APPROV.		
 DATASENSOR S.p.A. Via Lavino,265 40050 Monte S.Pietro - Bologna - Italy Tel:+39 051 6765611 Fax:+39 051 6759324 http://www.datasensor.com e-mail: Info@datasensor.com			DENOMINAZIONE			STAMPO			
			DIMENSIONI D'INGOMBRO R5					CODICE _____ REV.	
								SIGLA DIM-0067	